

**GENERATORE SCHIUMA AD ALTA ESPANSIONE Mod. AG – GEA VENT 1**  
**HIGH EXPANSION FOAM GENERATOR Mod. AG – GEA VENT 1**

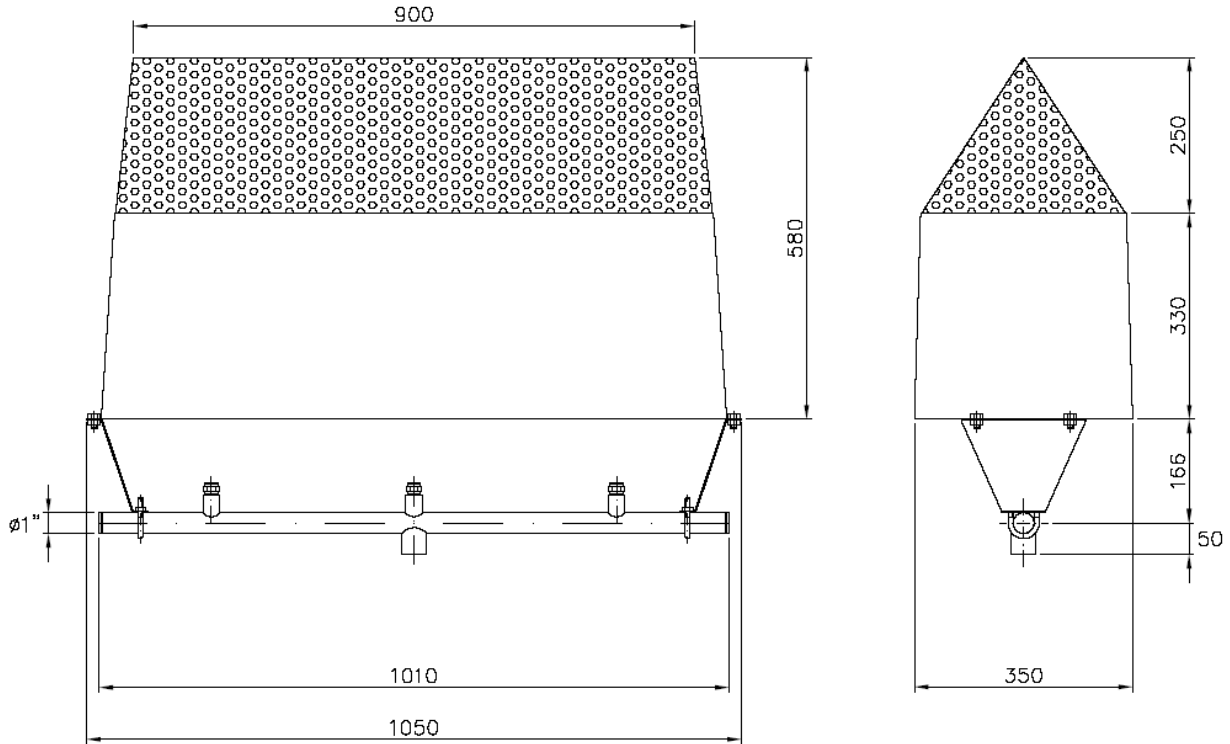

**CARATTERISTICHE COSTRUTTIVE**

Corpo: acciaio inox AISI 304

Ugelli : ottone

Tubo portaugello : A 106 GR.B

- Body: AISI 304 stainless steel

- Nozzles : brass

- Manifold : A 106 GR. b

<b>MODELLO</b> <i>MODEL</i>	<b>PRESS. DI ESERCIZIO</b> <i>WORKING PRESSURE</i>	<b>PORTATA</b> <i>FLOW RATE</i> L/MIN-5bar	<b>RAPPORTO DI ESPANSIONE</b> <i>EXPANSION RATIO</i> 5 bar	<b>PESO</b> <i>WEIGHT</i> KG
GEA VENT 1	5	90	1 : 450	14

**FOGLIO / SHEET N. 089**