



Model JL112 & J112 - Upright  
 ECLH - Extended Coverage Light Hazard  
 ECOH - Extended Coverage Ordinary Hazard  
 Hazard - Quick Response

Model JL112 & J112 ECLH/ECOH Upright  
 (SIN R7326 – Link and RA7326 – Bulb)

- Quick Response for Light Hazard (20' x 20' - 16' x 16' Spacing)
- Quick Response for Ordinary Hazard (14' x 14' - 12' x 12' Spacing)
- Standard Response for Ordinary Hazard (20' x 20' - 16' x 16' Spacing)

#### Features

1. Extended Coverage Ordinary Hazard protection to 400 ft<sup>2</sup> (37.2m<sup>2</sup>) per sprinkler.
2. Nominal K = 11.2 (160).
3. Available in brass, chrome and polyester coated finishes.
4. For applications as per NFPA 13.

#### Approvals Organizations

1. Underwriters Laboratories, Inc. (UL)
2. Underwriters Laboratories of Canada (cULus)
3. NYC MEA 258-93-E

#### UL Listing Category

Sprinklers, Automatic and Open Extended Coverage Sprinklers-Ordinary Hazard Occupancy UL Guide Number – VNIV.

The Model JL112 and J112 sprinkler are Extended Coverage Sprinklers for use in Ordinary Hazard 1 and 2 occupancies with a coverage area of up to 400 square feet per sprinkler. For ordinary hazard applications it is a Standard and Quick Response Sprinkler.

The use of ECLH/ECOH sprinklers can provide lower installation costs by requiring fewer sprinklers, less piping and reduced labor.

ECLH/ECOH sprinklers are to be installed according to the design criteria shown in this bulletin, NFPA 13, and all other local codes and ordinances. Flows and pressures as shown on pages 2 and 3 of this bulletin, must be used for the appropriate spacing and for the designated hazard classifications.

This ECLH/ECOH sprinkler is available in various finishes, which includes a white polyester corrosion resistant finish.

SIN RA 7326 is Corrosion Resistant with White Polyester Coating.



Model JL112 Upright  
 (R 7326) - Link



Model J112 Upright  
 (RA 7326) - Bulb

#### Design Criteria

Model JL112 & J112 ECLH/ECOH sprinklers shall only be used in systems designed and installed in accordance with NFPA 13 and all other local codes and ordinances. The following design criteria also apply:

- Minimum sprinkler spacing is 9 ft.
- Sprinklers have a minimum flow requirement for each spacing as shown in the Flow Requirements Table on the reverse side.
- ECOH sprinklers are only to be used in system hydraulically designed per NFPA 13 for a minimum area of 1500 ft<sup>2</sup> or 5 sprinklers, whichever is greater.
- Deflector to commodity clearance shall be a minimum of 18 in (457mm).
- ECOH sprinklers shall be installed in unobstructed constructions as defined in NFPA 13. For open web truss construction web thickness is not to exceed 1 inch.
- ECOH sprinklers which are installed above the bottom of a horizontal obstruction, shall have their deflectors located as shown in the Obstruction Table on page 3.
- Sprinklers can be installed under a sloping ceiling not exceeding 2 inches of rise in 12 inches.
- Maximum working pressure is 175 psi at the sprinkler.

## Sprinkler Model Specifications

Sprinkler Model	Type	Temperature Rating		Max. Ceiling Temp.		Maximum Sprinkler Spacing	Maximum Coverage Area	THD Size	Approvals
		°F	°C	°F	°C				
JL112 ECLH/ECOH- R7326	Upright	165	74	100	38	20'	400 ft <sup>2</sup>	¾" NPT	1,2
JL112 /ECOH- R7326	Upright	212	100	150	66				
J112 ECLH/ECOH- RA7326	Upright	155	68	100	38	20'	400 ft <sup>2</sup>		
J112 ECLH/ECOH- RA7326	Upright	200	93	150	66				

(1) For metric equivalent see Conversion Table.

## Flow Requirements - Ordinary Hazard - Standard Response

Spacing	Coverage Area	Ordinary Hazard 1		Ordinary Hazard 2		"K" Factor	
		0.15 gpm/ft <sup>2</sup> Density		0.20 gpm/ft <sup>2</sup> Density		US	Metric
		*Flow	*Pressure	*Flow	*Pressure		
16' x 16'	256 ft <sup>2</sup>	39	12.1	51	20.7	11.2	160.0
18' x 18'	324 ft <sup>2</sup>	49	19.1	65	33.7		
20' x 20'	400 ft <sup>2</sup>	60	28.7	80	51.0		

\* Flow is in gpm and pressure is in psi

(1) For metric equivalent see Conversion Table.

## Flow Requirements - Ordinary Hazard - Quick Response

Spacing	Coverage Area	Ordinary Hazard 1		Ordinary Hazard 2		"K" Factor	
		0.15 gpm/ft <sup>2</sup> Density		0.20 gpm/ft <sup>2</sup> Density		US	Metric
		*Flow	*Pressure	*Flow	*Pressure		
14' x 14'	196 ft <sup>2</sup>	30	7.2	39	12.1	11.2	160.0
12' x 12'	144 ft <sup>2</sup>						

\* Flow is in gpm and pressure is in psi

(1) For metric equivalent see Conversion Table.

(1) Conversion Table

1 in = 25.4 mm	1 gpm = 3.785 lpm
1 ft = 0.3048 m	1 gpm/ft <sup>2</sup> = 40.74 mm/mim
1 ft <sup>2</sup> = 0.093 m <sup>2</sup>	1 psi = 0.6895 bar

## Finishes

Sprinkler Finishes
Bronze
Chrome
White Polyester Coated

J1 Wrench



Model J1  
Sprinkler Wrench  
Use Model J1 Wrench for JL112 & J112  
ECLH/ECOH Upright Sprinkler  
Removal and Installation

## Ordering Information

1. Sprinkler Model
2. Temperature Rating
3. Finish

Corrosion Resistant		
J112 ECLH/ECOH	Bulb	
	°F	°C
	155	68
200	93	

### Minimum Flow Requirements For Earlier Editions of NFPA 13 - FOR REFERENCE ONLY

Spacing	Coverage Area	NFPA13 - 1991 Requirements				NFPA13 - 1989 Requirements						"K" Factor	
		Ordinary Hazard 1		Ordinary Hazard 2		Ordinary Hazard 1		Ordinary Hazard 2		Ordinary Hazard 3		US	Metric
		0.15 gpm/ft <sup>2</sup> Density		0.20 gpm/ft <sup>2</sup> Density		0.16 gpm/ft <sup>2</sup> Density		0.19 gpm/ft <sup>2</sup> Density		0.21 gpm/ft <sup>2</sup> Density			
		*Flow	*Pressure	*Flow	*Pressure	*Flow	*Pressure	*Flow	*Pressure	*Flow	*Pressure		
14' x 14' and less	196 ft <sup>2</sup>	30.2	7.0	39.2	11.9	31.4	7.6	37.3	10.7	41.2	13.0	11.4	164.4
16' x 16'	256 ft <sup>2</sup>	38.4	11.4	51.2	20.2	41.0	12.9	48.7	18.2	53.8	22.3		
18' x 18'	324 ft <sup>2</sup>	48.6	18.2	64.8	32.3	51.9	20.7	61.6	29.2	68.0	35.7		
20' x 20'	400 ft <sup>2</sup>	60.0	27.7	80.0	49.3	64.0	31.5	76.0	44.5	84.0	54.3		

\*Flow is in gpm and pressure is in psi

<sup>(1)</sup> For metric equivalent see Conversion Table .

### Flow Requirements - Light Hazard - Quick Response

Spacing	Coverage Area	Flow (gpm)	Pressure (psi)	"K" Factor	
				US	Metric
16' x 16'	256 ft <sup>2</sup>	30	7.2	11.2	160.0
18' x 18'	324 ft <sup>2</sup>	33	8.7		
20' x 20'	400 ft <sup>2</sup>	40	12.8		

<sup>(1)</sup> For metric equivalent see Conversion Table.

### Installation Requirements for Under Concrete Tees - cULus

- The stems of the concrete tee construction must be spaced at less than 7.5 feet (2.3m) on center but more than 3 feet (0.9m) on center. The depth of the concrete tees must not exceed 30 inches (762mm). The maximum permitted concrete tee length is 32 feet (9.8m); however, where the concrete tee length exceeds 32 feet (9.8m), non-combustible baffles, equal in height to the depth of the tees, can be installed so that the space between the tees does not exceed 32 feet (9.8m) in length.
- The sprinkler deflectors are to be located in a horizontal plane at or above 1 inch (25.4mm) below the bottom of the concrete tee stems.
- When the sprinkler deflectors are located higher than a horizontal plane 1 inch (25.4mm) beneath the bottom of the concrete tee stems, the obstruction to sprinkler discharge criteria requirements of NFPA13 for extended coverage upright sprinkler applies.

### Location of Deflector to Horizontal Obstruction

Distance from Sprinkler to Side of Obstruction	Maximum Allowable Distance Deflector Above Bottom of Obstruction
Less than 1'.....	0"
1' to less than 1' - 6".....	0"
1' - 6" to less than 2'.....	1"
2' to less than 2' - 6".....	1"
2' - 6" to less than 3'.....	1"
3' to less than 3' - 6".....	3"
4' to less than 4' - 6".....	5"
4' - 6" to less than 5'.....	7"
5' to less than 5' - 6".....	7"
5' - 6" to less than 6'.....	7"
6' to less than 6' - 6".....	9"
6' - 6" to less than 7'.....	11"
7' and greater.....	14"

(1) For metric equivalent see Conversion Table.

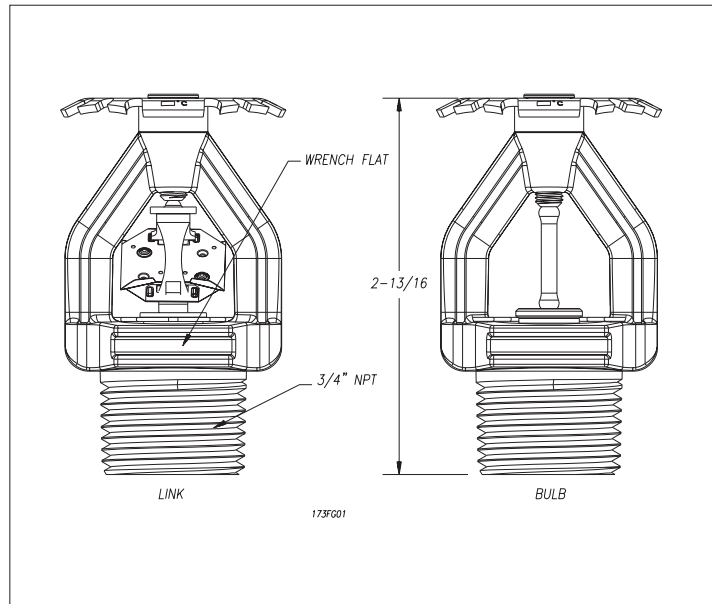

Fig. 1

Solder Link			Bulb			
Classification	°F	°C	Classification	°F	°C	Bulb Color
Ordinary	165	74	Ordinary	155	68	Red
*Intermediate	212	100	Intermediate	200	93	Green

\*Ordinary Hazard only

The equipment presented in this bulletin is to be installed in accordance with the latest pertinent Standards of the National Fire Protection Association, Factory Mutual Research Corporation, or other similar organizations and also with the provisions of governmental codes or ordinances, whenever applicable.